

TG611-13/-17 Governor

with Overspeed Test Device

Application

TG611 Governors are self-contained, mechanical-hydraulic, speed-droop governors for use on small steam turbines driving pumps, compressors, or generators, where isochronous (constant speed) operation is not required. These governors are directly coupled to the steam-turbine's rotor or auxiliary shaft to sense and control turbine speed. Designed for API-611-based turbine applications, these governors include a special Overspeed Test Device, allowing controlled and safe turbine overspeed trip testing.

Description

TG611 governors are mechanical-hydraulic speed-droop governors for controlling small steam turbines. These governors control turbine speed by sensing turbine rotor speed via their input drive shaft, comparing this speed to an internal speed setpoint, then using a rotary output terminal shaft connected to the turbine's governor valve to control turbine inlet steam flow. This self-contained governor utilizes an integrated drive-shaft-driven ballhead assembly to sense turbine speed, and an integrated drive-shaft-driven oil pump to create the necessary output force to move/control the turbine's governor valve. The governor output is a serrated terminal shaft that extends out each side of the governor housing and rotates up to 40° to accurately control the turbine's inlet steam valve(s).

Different models are available depending on the output shaft force and input drive-shaft speed range required. The TG611 governor's (turbine) speed setpoint is set and adjusted via a speed-setting screw located on the unit's cover plate. TG611 governors are available in two different work outputs: 16 N·m (12 lb-ft) and 23.7 N·m (17.5 lb-ft). These governors are hydraulically powered for a high work output, and are available for three different speed ranges.

Like most mechanical governors, the TG611 governor uses its output terminal shaft position as a feedback signal for stability. By using this stabilizing method, turbine speed will "droop" a certain percentage as load increases (shaft position increases).



- API 611 Compliant
- Low cost
- Speed droop control
- Integral overspeed test device
- Weatherproof
- Self-contained sump
- NEMA "A" speed control
- 16 and 23.7 N·m (12 and 17.5 lb-ft) outputs
- Designed for harsh environments

Standard Features

Simplicity and low cost are distinct advantages of the TG611 Governor. The governor operates with speed droop for stability of control and screw-type speed setting.

An internal oil pump, driven by the governor's drive shaft, transports oil from the self-contained sump. Internal pressure is maintained by a relief valve-accumulator system. An oil sight-glass provides ease in checking the oil level.

The output (terminal) shaft extends out both sides of the case, and the governor drive rotation can be in either direction.

Special Features

The built-in relief valve-accumulator helps maintain full oil pressure in the governor hydraulic system during transient conditions.

Contamination is reduced by the weatherproof construction and the self-contained oil sump.

The standard version includes an integral overspeed test device that allows the speed to be safely increased in a controlled manner up to the turbine's overspeed trip speed. This feature allows for testing of the turbine's overspeed trip mechanism in a safe manner.

Specifications

Speed-Setting Screw	Adjustment on top of cover
Input Drive Shaft Diameter	12.675 to 12.687 mm (0.4990 to 0.4995 inch)
Speed Range	Can be adjusted to meet NEMA "A" requirements at any speed within the following ranges: 1100 to 2400 rpm 2400 to 4000 rpm 4000 to 6000 rpm Different governor part numbers are required for different ranges.

IMPORTANT

This governor is capable of controlling at a lower-than-specified speed range with some loss of output torque and performance.

Drive Power Requirement	373 W (1/2 hp) maximum required to turn drive shaft at rated speed
Rotation	Clockwise or counterclockwise, as viewed from the top of the governor

IMPORTANT

Rotation can be changed on this governor by removing four screws and rotating pump housing 180°.

Output

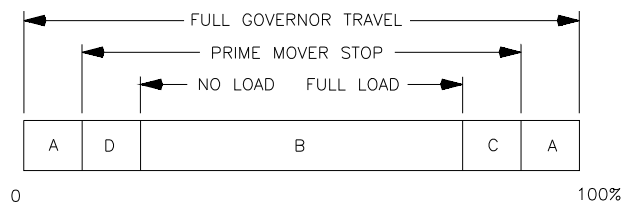
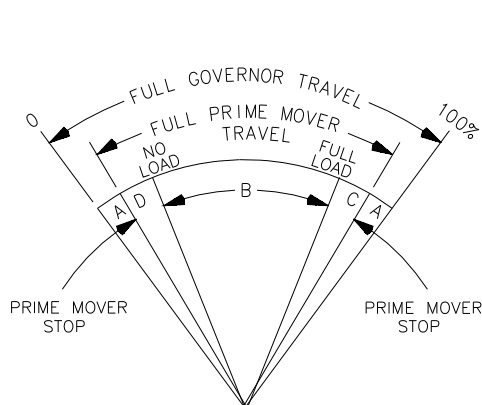

- A - OVERTRAVEL TO INSURE PRIME MOVER STOPS ARE REACHED.
- B - NO LOAD TO FULL LOAD TRAVEL - NORMALLY 2/3 OF FULL GOVERNOR TRAVEL IS RECOMMENDED.
- C - TRAVEL REQUIRED TO ACCELERATE THE PRIME MOVER.
- D - TRAVEL REQUIRED TO DECELERATE OR SHUT DOWN PRIME MOVER.

MI-153a
98-04-14 skw

MAXIMUM WORK CAPACITY OVER FULL GOVERNOR TRAVEL OF 42% IS * . SEE ABOVE FOR RECOMMENDED GOVERNOR OUTPUT TRAVEL. IN SPECIAL APPLICATIONS MIN AND MAX PRIME MOVER STOPS MAY BE OUTSIDE THE GOVERNOR STOPS.

TG611-13	16 N·m (12 lb-ft)
TG611-17	23.7 N·m (17.5 lb-ft)
Output Shaft	.625-36 serration on both sides of case

Control Characteristics

(intended to meet NEMA "A" requirements)

Steady State Speed Band	±0.75% of rated speed
Droop	Internally adjustable and must be set as required for stability. Factory set at 6% for 20° terminal shaft travel at 1800, 3600, or 5400 rpm, depending on speed range selected.
Typical Response	7.2% overspeed with full load change on a 50% per second acceleration turbine at 4% droop setting
Operating Temperature	Continuous operating temperature 60 to 93 °C (140 to 200 °F). Ambient temperature –29 to +93 °C (–20 to +200 °F). Contact Woodward if operating beyond these limits.

Overspeed Test Device

Range Adjustable	Overspeed test can be initiated from any speed setting Overspeed test speed can be set at any speed with a separate integral adjustment screw.
Semi-secure	Screw-on metal cap protects the overspeed test mechanism from the environment.

Hydraulic System

Oil	Self-contained sump. SAE 10 to 50 is recommended with a viscosity of 100 to 300 SUS, depending on operating temperature. See Woodward manual 25071, <i>Oils for Hydraulic Controls</i> , for recommended oils.
Relief Valve	An integral part of accumulator—it maintains 1034 kPa (150 psi) for the TG611-13 and 1379 kPa (200 psi) for the TG611-17 at the specified speed ranges. Both governors are capable of controlling at lower speeds with some loss of output torque and performance.
Capacity	1.7 L (1.75 quarts)

Construction

Case and Pump Housing	Die-cast aluminum
Weight	7 kg (16 lb) aluminum case

Mounting

Attitude	Vertical or horizontal (breather cap up)
----------	--

References

Manual 04042	<i>TG-13/TG-17/TG611-13/TG611-17 Governors</i>
Manual 25071	<i>Oils for Hydraulic Control</i>

Regulatory Compliance

European Compliance for CE Marking:

(Applicable only to units bearing the CE marking.)

ATEX Potentially Explosive Atmospheres Directive:	Declared to 94/9/EC COUNCIL DIRECTIVE of 23 March 1994 on the approximation of the laws of the Member States concerning equipment and protective systems intended for use in potentially explosive atmospheres as: II 2 G c IIC TX. The TX reflects special conditions for safe use:
--	--

Special Conditions for Safe Use—Maximum Surface Temperature

The maximum surface temperature of the TG611 Governor is dependent upon three factors that are specific to the operating conditions of each individual application. These factors are as follows:

- Governor drive shaft speed
- Ambient temperature
- Hydraulic Fluid Selection (see Table 2-1 in manual 04042)

The maximum surface temperature of the TG611 Governor must stay below the lowest ignition temperature of the surrounding explosive atmosphere and within allowable operating conditions for the hydraulic fluid selection. It is the user's responsibility to maintain a safe surface and fluid temperature. If normal operating conditions cause the surface temperature of the TG611 to rise close to ignition temperatures or near the maximum recommended hydraulic fluid temperature, a heat exchanger must be installed. Refer to manual 04042 for location and sizing of the ports for connection of a heat exchanger.

Other European Compliance

Compliance with the following European Directive does not qualify this product for the application of the CE Marking:

Machinery Directive:	Compliant as partly completed machinery with Directive 2006/42/EC of the European Parliament and the Council of 17 May 2006 on machinery.
Pressure Equipment Directive:	Compliant as "SEP" per Article 3.3 to Pressure Equipment Directive 97/23/EC of 29 May 1997 on the approximation of the laws of the Member States concerning pressure equipment.

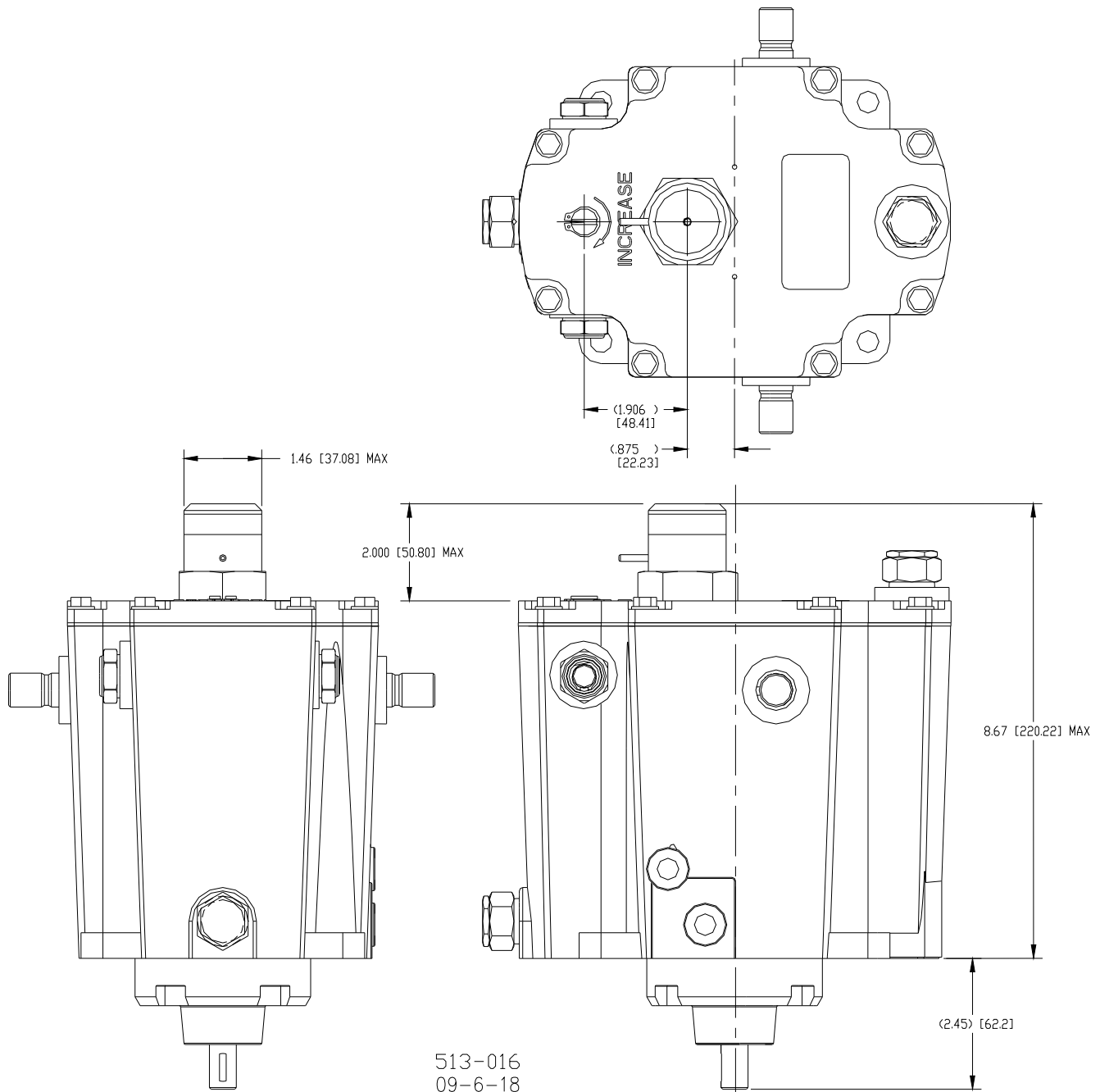

Outline Drawing of TG611 Governor



PO Box 1519, Fort Collins CO, USA 80522-1519
 1000 East Drake Road, Fort Collins CO 80525
 Tel.: +1 (970) 482-5811 ♦ Fax: +1 (970) 498-3058
www.woodward.com

Distributors & Service

Woodward has an international network of distributors and service facilities. For your nearest representative, call the Fort Collins plant or see the Worldwide Directory on our website.

This document is distributed for informational purposes only. It is not to be construed as creating or becoming part of any Woodward contractual or warranty obligation unless expressly stated in a written sales contract.

Copyright © Woodward 2009–2012, All Rights Reserved

For more information contact:



U.S. Toll Free 877-544-5201
 Lada S/C Mexico 888-418-DRAK (3725)
www.drakecontrols.com