

# CAN bus SAE J1939

## CAN bus option for LA36



To learn more about LINAK, please visit:  
[www.linak.com](http://www.linak.com)



# Contents

Preface .....	5
LINAK application policy.....	6
<b>About LINAK CAN bus actuators .....</b>	<b>7-19</b>
Summary.....	7
Revision history.....	7
Functional overview .....	8-9
Command details .....	10
Run in/out .....	10
Position .....	10
Maximum current in/out.....	10
Speed control.....	10
Status feedback details.....	11-12
Status flag feedback.....	11
Error code feedback .....	11
Position feedback.....	12
Current feedback .....	12
Soft start/stop.....	12
CAN bus specifications .....	13
Other parameters.....	13
Standards .....	13
Internal monitoring .....	14-15
Current limits and measurements .....	14
Voltage.....	15
Temperature .....	15
H-bridge .....	15
Parameters .....	15
Sleep mode .....	16
Environmental data and tests .....	17-18
Operational environment.....	17
Storage environment.....	17
Supply voltage .....	17
Power loss .....	17
Overvoltage .....	17
EMC.....	18
BusLink service interface.....	19

# Contents

<b>Installing LINAK CAN bus actuators</b> .....	20-34
Introduction .....	20
Connections .....	20
Single connector actuators .....	20
Dual connector actuators .....	20
Electrical installation .....	21-22
Manual run mode .....	22
Termination .....	22
Communication .....	23-27
Proprietary A .....	24
Proprietary B .....	25-26
Application Layer - Diagnostics .....	27-33
Diagnostics overview .....	28-30
Diagnostics trouble code (DTC) .....	31
Diagnostics examples .....	32-33
Network Management .....	34-35
Adresses .....	36

## **Preface**

Dear User,

We are delighted that you have chosen a product from LINAK®.

LINAK systems are high-tech products based on many years of experience in the manufacture and development of actuators, electric control boxes, controls, and chargers.

This user manual does not address the end-user, but is intended as a source of information for the manufacturer of the equipment or system only, and it will tell you how to install, use and maintain your LINAK electronics. It is the responsibility of the manufacturer of the end-use product to provide a User Manual where relevant safety information from this manual is passed on to the end-user.

We are sure that your LINAK product/system will give you many years of problem-free operation. Before our products leave the factory they undergo full function and quality testing. Should you nevertheless experience problems with your LINAK product/system, you are always welcome to contact your local dealer. LINAK subsidiaries and some distributors situated all over the world have authorised service centres, which are always ready to help you.

LINAK provides a warranty on all its products. This warranty, however, is subject to correct use in accordance with the specifications, maintenance being done correctly and any repairs being carried out at a service centre, which is authorised to repair LINAK products.

Changes in installation and use of LINAK products/systems can affect their operation and durability. The products are not to be opened by unauthorised personnel.

The User Manual has been written based on our present technical knowledge. We are constantly working on updating the information and we therefore reserve the right to carry out technical modifications.

**LINAK A/S**

## **LINAK application policy**

The purpose of the application policy is to define areas of responsibilities in relation to applying a LINAK product defined as hardware, software, technical advice, etc. related to an existing or a new customer application.

LINAK products as defined above are applicable for a wide range of applications within Medical, Furniture, Desk, and Industry areas. Yet, LINAK cannot know all the conditions under which LINAK products will be installed, used, and operated, as each individual application is unique.

The suitability and functionality of the LINAK product and its performance under varying conditions (application, vibration, load, humidity, temperature, frequency, etc.) can only be verified by testing, and shall ultimately be the responsibility of the LINAK customer using any LINAK product.

LINAK shall be responsible solely that LINAK products comply with the specifications set out by LINAK and it shall be the responsibility of the LINAK customer to ensure that the specific LINAK product can be used for the application in question.

# About LINAK CAN bus actuators



## Summary

This document describes the capabilities of LINAK TECHLINE CAN bus components and the requirements for controlling these. It specifies the technologies involved, the environmental data specification and the functional description.

LINAK TECHLINE CAN bus actuators are primarily designed with focus on mobile agriculture and industrial automation.

The communication protocol relies on the SAE J1939 standard. The contents of this document assume the reader is familiar with the SAE J1939 standard.

Each LINAK actuator with CAN bus interface has the ability to act as a CAN bus node in the CAN bus cluster. The CAN bus actuator is able to provide feedback information about the piston position, error codes and other information. It also provides system identification data and actual current at runtime. It is also possible to send input commands to the system and invoke actuator movement based on direction.

## Revision history

The following documentation supports this software release:  
LA36CAN prototype: SW0105000V0-2933

## Functional overview

The LINAK TECHLINE CAN bus offers a command set for controlling the actuator. This is split up into Commands and Configuration Management (Proprietary A), Status (Proprietary B) and diagnostics.

<b>J1939 Proprietary A</b>	<b>Commands and Configuration Management</b>	
	Commands	Run forward/backward/to position/stop
	Setup values	Current limit in/out Max. speed
<b>J1939 Proprietary B</b>	<b>Status</b>	
	Running status	Current Position
	Status flags	Direction Position Endstop reached Overcurrent
	Counters	Number of endstops Number of starts
	Error status	Hall sensor Overvoltage Undervoltage CAN communication End of stroke Power on block state Overtemperature

Table 1. Command set, configuration management and status feedback.



## Functional overview

SAE J1939-73 Diagnostics	Diagnostics	
	Setup	Actuator address CAN bus transmission rate
	Identification	Unique ID number (UIN) Software ID Production order number Production date
	Historic values	Max. current recorded Max./min. temperatures recorded
	Usage	Current/time [A-s] Runtime
	Reason for last stop	Overtemperature Over/undervoltage Overcurrent Component error Communication error

Table 2. Diagnostics setup.

## Command details

### Run in/out

In and out movement is performed by sending the proper identifier while the actuator is in CAN bus mode. In Service mode, movement is achieved by using the LINAK BusLink PC software or by applying the proper signals to the Manual run wires. When the actuator is in CAN bus mode, Service mode and manual run is disabled. Using manual run, a start-up delay of up to 150 ms must be expected due to safety measures.

### Position

The actuator will drive to the set position.

Max/min. position: Stroke length

Level setting steps: 0.1 mm

Load and ramping up and down should be taken into account in regard to accuracy.

### Maximum current in/out

Applying a current limit will induce a degree of mechanical overload protection to the installation.

Max. current limit: Fixed limit\*

Level setting steps: 0.25 A

\*The custom current limit setting cannot overrule the fixed factory setting which insures partially protection of the electronics and mechanics. See Internal monitoring page 14 for details.

### Speed control

The speed is controlled using PWM.

Min. duty cycle: 0 %

Max. duty cycle: 100 %

Level setting steps: 0.5 %

Closed loop speed control will ensure a more accurate speed. In order to obtain this, the maximum speed is reduced to approximately 80%. The actual speed will be influenced by the gear and spindle size in the actuator.

## Status feedback details

A number of status parameters can be observed while the actuator is *not* in sleep mode.

### Status flag feedback

Value	Function	Comment
0	EOS in	The actuator has reached the physical or virtual endstop in
1	EOS out	The actuator has reached the physical or virtual endstop out
2	Overcurrent *	The actuator has measured a current larger than permitted for a longer period of time than allowed
3	Running out	Will indicate that the actuator is running outwards
4	Running in	Will indicate that the actuator is running inwards
5	Reserved	Always 1
6	Reserved	Always 1
7	Reserved	Always 1

Table 3. Status flags overview.

\* An Overcurrent flag will prevent the actuator from further movement in the same direction. To clear the flag, order the actuator to run in the opposite direction.

### Error code feedback

Value	Function	Comment
0	No error	No error detected
1	Hall error	Hall position sensor or magnet is not responding as expected
2	Overvoltage	The actuator has measured a voltage larger than permitted
3	Undervoltage	The actuator has measured a voltage lower than permitted while running
4	Failed to Keep CAN signal alive	Failed to maintain <i>CAN keep alive signal</i> . No Configuration Message received for 3 seconds while in a run condition
5	EOS error	The actuator is experiencing unexpected behaviour
6	Power on Block State	Must be cleared after power up. This will prevent an unintentional movement
7	Temperature error	One of the two temperature sensors report a higher temperature than permitted

Table 4. Error codes overview.

\* Error codes must be cleared in order to continue, except Error 6 'Power on Block State' which must be cleared using the 'Stop' command. Error codes are enumerated, indicating the active error of the highest priority.

## Status feedback details

### Position feedback

Value	Function	Comment
0 - 64255	Position	Position in 1/10 <sup>th</sup> mm
65024	Position lost	Position discrepancy or actuator is not initialised

Table 5. Position feedback overview.

### Current feedback

Value	Function	Comment
0	Not running	Current level is indicating no activity
1 - 250	Current	Measured motor current

Table 6. Current feedback overview.

### Soft start/stop

To reduce mechanical stress, a ramp up and ramp down time can be set in both directions.

Hard stop                      0 sec  
Min. ramp time:            300 ms  
Max. ramp time:            30 sec.

A ramp down time between 0 and 300 ms is not allowed in order to minimise the effect of back EMF from the motor.

## CAN bus specifications

This section describes the requirements of the CAN bus hardware and software interface.

The physical layer is in accordance with J1939-15.

Speed	250 kbps
Max. bus length	40 metres
Max. stub length	3 metres
Max. node count	10 (30*)
Wiring	Unshielded twisted pair
Cable impedance	120 $\Omega$ ( $\pm 10\%$ )

The maximum cable length delivered by LINAK is not longer than 3 metres. Consequently, all system tests carried out are limited to consist of 3 meter cables.

\* The SAE J1939-15 can accept up to 30 nodes. See section 3.1 of J1939-15 May 2014 for details.

### Other parameters

Non-error tolerant physical layer with the following specifications: Low-power mode is according to ISO 11898-5.

### Standards

The following standards and revisions are the bases of the LINAK TECHLINE® CAN bus software:

- SAE J1939-21 DEC2010      Data Link Layer
- SAE J1939-31 APR2014      Network Layer
- SAE J1939-71 APR2014      Application Layer
- SAE J1939-73 JUL2013      Application Layer – Diagnostics  
DM14 (Memory access request)  
DM15 (Memory access response)  
DM16 (Binary data transfer)
- SAE J1939-81 JUN 2011      Network Management
- SAE J1939-82 AUG 2008      Compliance - Truck and bus\*\*

\*\* Complies with relevant parts of the SAE J1939-82.

# Internal monitoring

A number of parameters are monitored during operation to prevent overloading the electronics and to minimise the risk of mechanical damage.

## Current limits and measurements

The principle behind the current measurement is an 'above limit' and 'below limit' accumulating counter. When the Timeout counter reaches a specific value the current cut-off goes into effect. The timeout value is pre-set at 200ms but it is configurable.

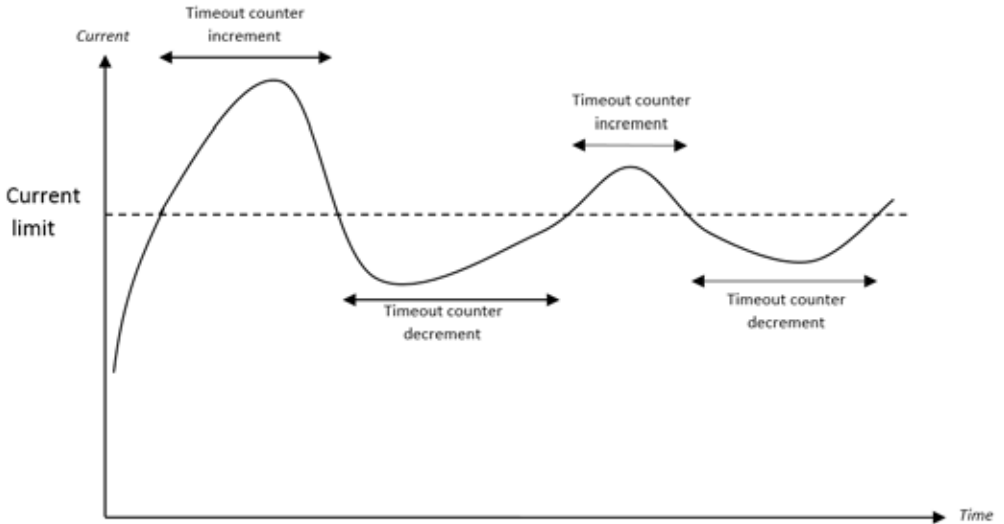

Figure 1. Dynamic current limit principle.

In case of current limit activation (Timeout counter max is reached), the actuator will stop and an over current error is triggered. The error is cleared when the actuator is activated in the opposite direction or by issuing a Clear error command.

Motor current measurements and factory limits for the LA36CAN are:

For a 12 VDC version LA36CAN: 30A

For a 24 VDC version LA36CAN: 20A

Custom over current limit can only be lower than or equal to the fixed factory setting.

# Internal monitoring

## Voltage

The supply voltage level is monitored in order to maintain a safe operation and to protect the circuitry.

## Temperature

Two temperature monitoring circuits are in place to measure the absolute temperature of the board and the centre temperature of the H-bridge.

## H-bridge

The H-bridge conditions are monitored at all times. Several conditions are required in order to run. Among these are:

- Correct voltage supplies
- Heartbeat safety signal
- Correct temperatures
- No errors

## Parameters

In addition to the immediate monitoring, a number of parameters are saved for long-term evaluation. These include:

- Number of starts in either direction
- Reason for last stop
- Total running time
- Under and over voltage
- Maximum current
- Number of current overloads in either direction

These parameters will help the engineer sort out existing issues. Considering a combination of parameter values, the lifetime load can indicate a potential failure before it happens and thereby prevent downtime.

## Sleep mode

The sleep and wakeup functionality is according to ISO11898-5. The current consumption in sleep mode is:

Sleep mode current consumption			
Supply voltage	25 °C	60 °C *	85 °C *
12 V	100 µA	(1.0 mA)	(1.2 mA)
24 V	250 µA	(2.0 mA)	(2.4 mA)

Table 3. Sleep mode current consumption.

\* The current consumption at 60°C - 85°C is subject to change.

### Entering sleep mode

The actuator will enter sleep mode after a preset default time of 5 min. Conditions for entering sleep mode are one of the following:

- No CAN bus activity
- No Service interface activity
- No manual drive activity

### Exiting sleep mode

- Any CAN bus activity
- Service interface activity
- Activating manual run
- Power up



## Environmental data and tests

The CAN bus actuators fulfil the environmental requirements as defined:

### Operational environment

Ambient temperature: -30°C to 65°C (full performance only from +5°C to 40°C)  
Relative humidity: 30% to 80% @ 30°C  
Pressure: 700hPa to 1060hPa

### Storage environment

Ambient temperature: -55°C to 105°C  
Relative humidity: 30% to 80% @ 30°C  
Pressure: 700hPa to 1060hPa

### Supply voltage

The actuator will be available in two supply voltage ranges, 12 VDC and 24 VDC. The accepted supply voltage range is specified according to ISO16750-2012.

Supply voltage	V <sub>MIN</sub>	V <sub>TYP</sub>	V <sub>MAX</sub>	Reference	Note
12 V	10.5 V	12 V	16 V	ISO 16750-2:2012 - Code D	Motor running
	6 V	12 V	16 V	ISO 16750-2:2012 - Code A	Motor not running CAN communication possible
24 V	18 V	24 V	32 V	ISO 16750-2:2012 - Code H	Motor running
	10 V	24 V	32 V	ISO 16750-2:2012 - Code E	Motor not running CAN communication possible

Table 4. Voltage supply levels.

### Power loss

In case of power loss, the actuator position and other important data is saved by the on-board microcontroller.

### Over voltage

If the voltage rises above approx. 40 volts, the system will enter overvoltage protection mode and shut down.

# Environmental data and tests

## EMC

The Electromagnetic Compatibility tests performed on the LINAK CAN bus actuator comply with the TECHLINE® Electrical Test Specification. The scope of tests are verified and accredited by DELTA A/S test laboratory.

Norm/Standard	Test decription
ISO 16750-2:2012	Supply voltage range
	Overtoltage
	Superimposed alternating voltage
	Slow lowering and raising the voltage supply
	Momentary drop in supply voltage
	Reset behaviour for voltage drop
	Reversed voltage
	Ground reference and supply offset
	Open circuit test
	Short circuit protection
	Load dump – Test pulse 5a
	Load dump test pulse 5b
ISO 7637-2:2011	Test pulse 1
	Test pulse 2a
	Test pulse 2b
	Test pulse 3a
	Test pulse 3b
ISO 16750-2:2012	Test pulse 4
ISO 7637-2:2011	Voltage transient emission test on power supply lines
ISO 7637-3:2007	Electric transient transmission by cap. and inductive coupling
CISPR 25 IEC:2008	Conducted disturbance voltage measurement
	Radiated emission – ALSE method
CISPR 16-1-2:2010	Conducted emission
CISPR 16-2-3:2010	Radiated emission
ISO 10605 2 <sup>nd</sup> Ed.	ESD immunity
IEC 61000-4-2 2 <sup>nd</sup> Ed.	ESD immunity
ISO 11452-1:2005, ISO 11452-2:2004, ISO 11452-4:2011, ISO 11452-5:2002	Interference immunity
IEC 61000-4-3:2006	Interference fields immunity test
IEC 61000-4-8:2010	Power frequency magnetic field
IEC 61000-4-4:2004	Burst transients
IEC 61000-4-5:2006	Surge transients

Table 5. LINAK TECHLINE EMC test overview.

## BusLink service interface

The BusLink service interface offers a wide range of settings and status feedback options. Use the LINAK USB2LIN cable and the LINAK BusLink PC software will gain access to:

### BusLink settings

- Initialisation
- Current limit settings
- Soft start/stop timing

### BusLink feedback

- Run time parameters
- Number of starts and stops
- Maximum current and temperature
- Error messages

The actuator can also be run manually using BusLink control interface. During normal CAN operation, BusLink manual run is disabled. The service interface is only intended to run with the BusLink PC software tool.



Figure 2. LINAK USB2LIN service cable.

See the [BusLink Quick Guide](#) for details on how to connect to the specific actuator model.

The USB2LIN service cable and adapter cable suitable for LA36CAN can be ordered as PN: 0367997.

# Installing LINAK CAN bus actuators

## Introduction

This section will assist you in the installation of the LINAK CAN bus actuator. Going through parameters and procedures necessary for a successful implementation.

- Connections
- Electrical installation
- Communication
- Start-up procedures (not included in this version)

## Connections

The tables below define the wire connections to the LINAK TECHLINE® CAN bus actuators. These colours are consistent with all LINAK TECHLINE CAN bus actuators.

### Single connector actuators

Power connector, 8-pin mini-fit connector

LINAK cable	Description
Brown	+ Power supply (12/24VDC)
Blue	- Power supply (GND)
Black	Manual run in
Red	Manual run out
White	Service interface GND
Purple	Service interface DATA
Yellow	CAN H
Green	CAN L

Table 6. Power and communication wire colour.

### Dual connector actuators

Power connector, 6-pin mini-fit connector

LINAK cable	Description
Brown	+ Power supply (12/24VDC)
Blue	- Power supply (GND)

Table 7. Power wire colours.

Communication connector, 6-pin micro-fit connector

LINAK cable	Description
Black	Manual run in
Red	Manual run out
White	Service interface GND
Purple	Service interface
Yellow	CAN H
Green	CAN L

Table 8. Communication wire colours.

By default, cables are supplied with flying leads.

# Electrical installation

The J1939-15 defines the Reduced Physical Layer, 250K bits/sec, Un-Shielded Twisted Pair (UTP) and runs with separate communication and power supply wires.

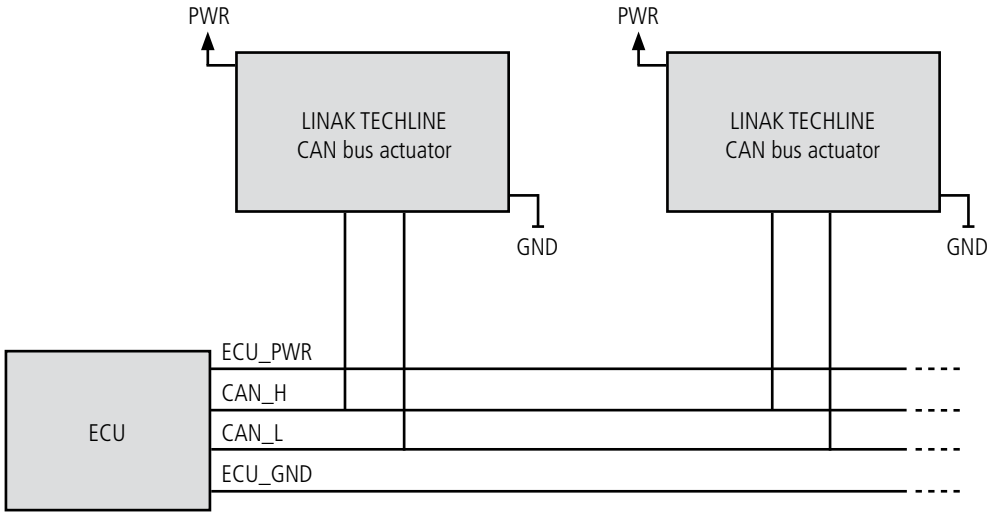

Figure 3. Power supply connection setup.

The power supply for the LINAK CAN bus actuator should be kept separate from the CAN bus power supply, if such one exists.

# Electrical installation

## Manual run mode

If manual run mode is engaged, the Service interface is enabled.

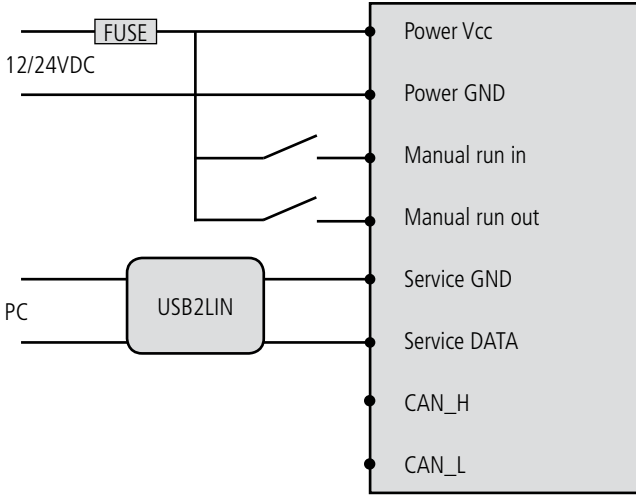

Figure 4. Manual run connection diagram.

## Termination

Termination resistors of 120 Ω are connected according to the figure below.

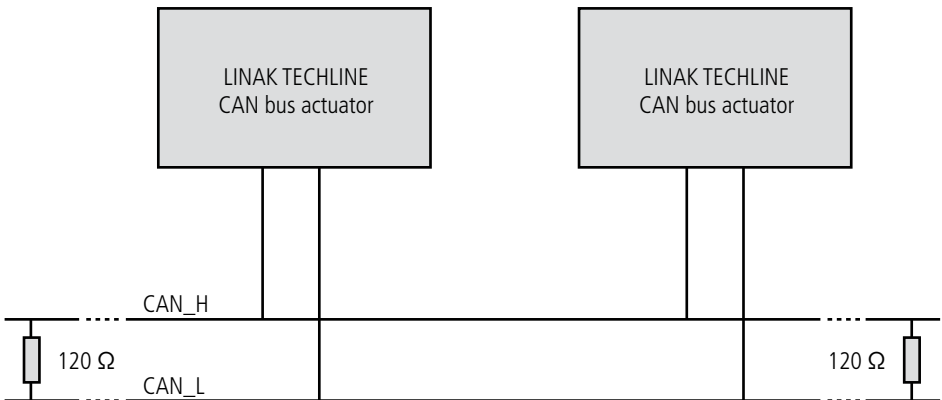

Figure 5. Manual run connection diagram.

## Communication

The installation must be performed by qualified personnel with knowledge of CAN bus communication and the SAE J1939 standard. Only the sections of the standard which are relevant for the installation will be discussed.

- SAE J1939-21 Data Link Layer Proprietary A, Proprietary B
- SAE J1939-73 Application Layer Diagnostics
- SAE J1939-81 Network Management

### Test

LINAK can provide a test script compiled for the Vector VN16xx interface family and a PC application, supporting the PCAN interface from PEAK Systems.

### Data range definition

Range name	1 byte	2 bytes
Valid signal	0 - 250 0x00 - 0xFA	0 - 64255 0x0000 - 0xFAFF
Parameter specific indicator	251 0xFB	64256 - 64511 0xFB00 - 0xFBFF
Reserved range for future indicator bits	252 - 253 0xFC - 0xFD	64512 - 65023 0xFC00 - 0xFDFF
Error indicator	254 0xFE	65024 - 65279 0xFE00 - 0xFEFF
Not available, not installed or not requested	255 0xFF	65280 - 65535 0xFF00 - 0xFFFF

# Communication

## Proprietary A

Function:	General request
Description	Write to proprietary A to clear error state, run out, run in or run to a specific position in addition to setting speed and current limit..
Min. transmission rate	250ms
PGN	0x00EF00

### Data field

8 bytes containing all changeable data.

B7 (Sent last)	B6	B5	B4	B3	B2	B1	B0 (Sent first)
Reserved, write 0xFF	Reserved, write 0xFF	Reserved, write 0xFF	Reserved, write 0xFF	Speed [%*0.5]	Current [mA *250]	Position [mm*0.1] MSB	Position LSB

### Data field definition

Byte(s)	Name	Details	SLOT
<b>B4-B7</b>	Reserved	Always write 0xFF	Not applicable
<b>B3</b>	Speed	0-199 Speed to use (0.5%/bit: 0%-99.5%) 200-250 Use 100% speed 251 Actuator default value 252-255 Reserved. Do not run, regardless of other bytes in request	SLOT 299: SAEpc18 (0% - 125%)
<b>B2</b>	Current	0-250 Maximum current to use 251 Actuator default value 252-255 Reserved. Do not run, regardless of other bytes in request	SLOT 410: SAEec09 (0.25 A/bit: 0.0A - 62.5A)
<b>B0-B1</b>	Position	0-64255 Run to position 64256 Clear ErrorCode register 64257 Command run to actuator out 64258 Command run to actuator in 64259 Command stop actuator* 64260-65535 Reserved. Do not run, regardless of other bytes in request	SLOT 283: SAEmd01 (0.1 mm/bit: 0mm - 6.43m)

\* This command is mandatory after power-up and communication time-out (5s).



# Communication

## Proprietary B

Function: General status  
Description: Read status parameters, motor current and actuator piston position.  
Min. transmission rate: 100ms  
PGN: 0x00FF00, 65280d

### Data field

8 bytes containing all status information.

<b>B7 (Sent last)</b>	<b>B6</b>	<b>B5</b>	<b>B4</b>	<b>B3</b>	<b>B2</b>	<b>B1</b>	<b>B0 (Sent first)</b>
Reserved, always 0xFF	Reserved, always 0xFF	Reserved, always 0xFF	ErrorCode: 8-bit error code	StatusFlags: Bit-field	Current [mA *250]	Position [mm*0.1] MSB	Position LSB

# Communication

## Proprietary B

### Data field definition

Byte(s)	Name	Details	SLOT
<b>B5-B7</b>	Reserved	Always reads 0xFF	Not applicable
<b>Bits 24-31 B4</b>	ErrorCode	8-bit error code indicating the currently active error of highest priority 0 = No error 1 = Hall error 2 = Overvoltage 3 = Undervoltage 4 = Failed to maintain CAN keep alive signal 5 = EOS error 6 = Power on block state 7 = Temperature error 8 = Heart beat error (internal) 9 = SMPS error (internal)	Not defined
<b>Bits 32-39 B3</b>	StatusFlags	8 independent status bit-indicators b0 = EOS in b1 = EOS out b2 = Overcurrent b3 = Running out b4 = Running in b5 = Reserved b6 = Reserved b7 = Reserved	Not defined
<b>Bits 40-47 B2</b>	Current	Measured motor current 0 Not running 1-250 Measured motor current 251-253 Reserved 254 Fault in current measurement circuit 255 Reserved	SLOT 410:SAEec09 (0.25 A/bit: 0.25A - 62.5A)
<b>Bits 48-63 B0-B1</b>	Position	Position feedback 0-64255 Position of actuator piston 64256-65023 Reserved 65024 Position lost 65025-65535 Reserved	SLOT 14: SAEs04 (0.1 mm/bit: 0mm - 6.43m)

## Application Layer - Diagnostics

The following Diagnostics Messages are used in the retrieval of diagnostics data according to SAEJ1939-73 section 5.7.14.1.2.

DM14 Memory access request  
DM15 Memory access response  
DM16 Binary data transfer

Pointer type:           1 = Directed spatial addressing (parameter IDX)  
Pointer extension:    0 = SPM space

### Return codes

The status return code for any diagnostics function indicating an error or warning.

0x01 = OK
0x80 = Invalid parameter index
0x81 = Invalid action code
0x82 = Write access denied
0x83 = Value underflow
0x84 = Value overflow
0x85 = Invalid enumerator value

# Application Layer - Diagnostics

## Diagnostics overview

Pointer/ IDX	Data size	Description	SLOT Id	SLOT name	Access	Example	Meaning
		Setup values					
516096	U8	Current limit out [mA*250]	410	SAEec09	R/W	60	15A
516097	U8	Current limit in [mA*250]	410	SAEec09	R/W	24	6A
516098	U16	Soft start time out [ms]	132	SAEtm02	R/W	1500	1.5s
516099	U16	Soft start time in [ms]	132	SAEtm02	R/W	500	500ms
516100	U16	Soft stop time out [ms]	132	SAEtm02	R/W	2000	2s
516101	U16	Soft stop time in [ms]	132	SAEtm02	R/W	300	300ms
516102	U16	Maximum speed [%*0.5]	299	SAEpc18	R/W	180	90%
516103	U16	Virtual EOS out posi- tion [mm * 0.1]	14	SAEds04	R/W	2000	200mm
516104	U16	Virtual EOS in position [mm * 0.1]	14	SAEds04	R/W	50	5mm
516105	U8	Actuator address	35	SAEsa01	R/W	123	123
516106	U16	Can-bus speed [Manufacturer defined: Kbit/s] (Allowed values are: 250)	283	SAEmd01	R/W	250	250Kbit/s
		Identification					
516107	U32	UIN	283	SAEmd01	R	12345678	Serial number
516108	String[20]	Software identifica- tion (SW variant/ build number) [ASCII, text (variable, NULL delimited)]	258	SAEatnd0200	R	SW123456 7V1-1234	SW variant 1234567 version 1 build 1234
516109	String[20]	Production order number [ASCII, text, variable, NULL delim- ited]	258	SAEatnd0200	R		
516110	U32	Production date	283	SAEmd01	R	20150728	July 28th 2015

## Application Layer - Diagnostics

### Diagnostics overview

Pointer/ IDX	Data size	Description	SLOT Id	SLOT name	Access	Example	Meaning
		Historic values					
516110	U8	Maximum current seen [mA*250]	410	SAEec09	R	61	15.25A
516111	S16	Maximum FET temperature seen [°C - 40]	67	SAEtp01	R	138	98°C
516112	S16	Maximum ambient temperature seen [°C - 40]	67	SAEtp01	R	82	42°C
516113	S16	Minimum ambient temperature seen [°C - 40]	67	SAEtp01	R	36	-4°C
		Usage totals					
516114	U32	Current usage [As]	283	SAEmd01	R	21605	Total power consumed: 6Ah
516115	U32	Run-time [s]	64	SAEtm05	R	4321	Total running time: 1h12m1s

## Application Layer - Diagnostics

### Diagnostics overview

Pointer/ IDX	Data size	Description	SLOT Id	SLOT name	Access	Example	Meaning
		Reason for last stop, stop counters and communication error counter					
516116	U16	Reason for last stop	64	SAEtm05	R	2	Overtemperature
516117	U8	Overvoltage stops	133	SAEct03	R		
516118	U8	FET overtemperature stops	133	SAEct03	R		
516119	U8	Ambient overtemperature stops	133	SAEct03	R		
516120	U8	Low voltage stops	133	SAEct03	R		
516121	U8	Hall error stops	133	SAEct03	R		
516122	U8	EOS switch error stops	133	SAEct03	R		
516123	U8	LINAK current overloads out stops	133	SAEct03	R		
516124	U8	LINAK current overload in stops	133	SAEct03	R		
516125	U8	Custom current overloads out stops	133	SAEct03	R		
516126	U8	Custom current overload in stops	133	SAEct03	R		
516127	U16	Communication errors	208	SAEct05	R		
		Activation counters					
516128	U16	Number of EOS in	208	SAEct05	R		
516129	U16	Number of EOS out	208	SAEct05	R		
516130	U32	Number of starts in	209	SAEct07	R		
516131	U32	Number of starts out	209	SAEct07	R		

## Application Layer - Diagnostics

### Diagnostic Trouble Code (DTC)

SPN	Name	FMI
0x7e400	Actuator	FMI3 = Voltage above normal or shorted to high
0x7e401	Actuator	FMI4 = Voltage below normal or shorted
0x7e402	Actuator	FMI6 = Current above normal or shorted to high
0x7e403	FET Temp	FMI15 = Data valid, but above normal operating range (least significant level)
0x7e404	AMB Temp	FMI15 = Data valid, but above normal operating range (least significant level)







# Network Management

Processes and messages are associated according to SAEJ1939-81 Section 4.2.1.1.

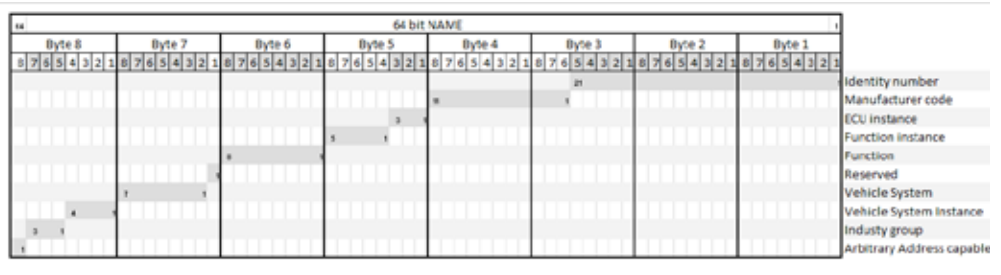

- (1) The serial number contained in the Identity number is a unique ID assigned to each actuator.
- (2) ECU instance can be utilised if two or more ECU's are present on the network.
- (3) Function instance is suitable when two or more actuators are present on the same network where the actuators only differ on e.g. Left and Right.

Parameter Name	Size in Bits	Start Byte	Start Bit	Details
Identity Number	21	1	1	Lower 21 bits of UIN (Unique Serial Number)
Manufacturer Code	11	3	6	690 (LINAK A/S)
ECU Instance	3	5	1	Default 0
Function Instance	5	5	4	Determined by address strapping, Section 2.1.14.3 (2.3.3)
Function	8	6	1	Default 132 (Utility Machine Control)
Reserved	1	7	1	Always 0
Vehicle System	7	7	2	Default 24 (Utility Vehicles)
Vehicle System Instance	4	8	1	Configurable from 0-15
Industry Group	3	8	5	Default 2 (Agriculture and Forestry Equipment)
Arbitrary Address Capable	1	8	8	Always 1: Capable of selecting source address

# Network Management

Examples

CAN identifier

<input type="checkbox"/>	CAN-ID	Type	Length	Data
Receive	00EEFFC8h		8	78 56 44 56 00 84 30 A0
	18FF00C8h		8	42 00 00 E0 00 FF FF FF

- 18 Priority, Reserved bit and Data page
- FF00 Parameter format (PF) and Parameter Specific (PS)
- C8 Source Address (SA)

## FACTORIES

### CHINA

LINAK (Shenzhen) Actuator Systems, Ltd.  
Phone: +86 755 8610 6656  
Fax: +86 755 8610 6990  
E-mail: sales@linak.cn  
www.linak.cn

### DENMARK

LINAK A/S - Group Headquarters, Guderup  
Phone: +45 73 15 15 15  
Fax: +45 74 45 80 48  
Fax: +45 73 15 16 13 (Sales)  
E-mail: info@linak.com  
www.linak.com

### SLOVAKIA

LINAK Slovakia s.r.o.  
Phone: +421 51 75 63 414  
Fax: +421 51 75 63 410  
E-mail: jp@linak.sk  
www.linak.com

### USA

LINAK U.S. Inc.  
North and South American Headquarters  
Phone: +1 502 253 5595  
Fax: +1 502 82 92 90  
E-mail: info@linak-us.com  
www.linak-us.com

## SUBSIDIARIES

### AUSTRALIA

LINAK Australia Pty. Ltd  
Phone: +61 3 8796 9777  
Fax: +61 3 8796 9778  
E-mail: sales@linak.com.au  
www.linak.com.au

### AUSTRIA

LINAK Repräsentanz  
Österreich (Wien)  
Phone: +43 (1) 890 7446  
Fax: +43 (1) 890 744615  
E-mail: info@linak.de  
www.linak.at

### BELGIUM & LUXEMBOURG

LINAK Actuator-Systems NV/SA  
Phone: +32 (0)9 230 01 09  
Fax: +32 (0)9 230 88 80  
E-mail: beinfo@linak.be  
www.linak.be

### BRAZIL

LINAK Do Brasil Comércio De Atuadores Ltda.  
Phone: +55 (11) 2832 - 7070  
Fax: +55 (11) 2832 - 7060  
E-mail: info@linak.com.br  
www.linak.com.br

### CANADA

LINAK Canada Inc.  
Phone: +1 502 253 5595  
Fax: +1 416 255 7720  
E-mail: info@linak.ca  
www.linak-us.com

### CZECH REPUBLIC

LINAK C&S S.R.O.  
Phone: +420581741814  
Fax: +420581702452  
E-mail: ponizil@linak.cz  
www.linak.cz

### DENMARK

LINAK Denmark A/S  
Phone: +45 86 80 36 11  
Fax: +45 86 82 90 51  
E-mail: linak@linak-silkeborg.dk  
www.linak.dk

### FINLAND

LINAK OY  
Phone: +358 10 841 8700  
Fax: +358 10 841 8729  
E-mail: linak@linak.fi  
www.linak.fi

### FRANCE

LINAK France E.U.R.L.  
Phone: +33 (0) 2 41 36 34 34  
Fax: +33 (0) 2 41 36 35 00  
E-mail: linak@linak.fr  
www.linak.fr

### GERMANY

LINAK GmbH  
Phone: +49 6043 9655 0  
Fax: +49 6043 9655 60  
E-mail: info@linak.de  
www.linak.de

### INDIA

LINAK A/S India Liaison Office  
Phone: +91 120 4734613  
Fax: +91 120 4273708  
E-mail: info@linak.in  
www.linak.in

### IRELAND

LINAK UK Limited - Ireland  
Phone: +44 (0)121 544 2211  
Fax: +44 (0)121 544 2552  
+44 (0)796 855 1606 (UK Mobile)  
+35 387 634 6554 (Republic Of Ireland Mobile)  
E-mail: sales@linak.co.uk  
www.linak.co.uk

### ITALY

LINAK Italia S.r.l.  
Phone: +39 02 48 46 33 66  
Fax: +39 02 48 46 82 52  
E-mail: info@linak.it  
www.linak.it

### JAPAN

LINAK K.K.  
Phone: 81-45-533-0802  
Fax: 81-45-533-0803  
E-mail: linak@linak.jp  
www.linak.jp

### MALAYSIA

LINAK Actuators Sdn. Bhd.  
Phone: +60 4 210 6500  
Fax: +60 4 226 8901  
E-mail: info@linak-asia.com  
www.linak.my

### NETHERLANDS

LINAK Actuator-Systems B.V.  
Phone: +31 76 5 42 44 40  
Fax: +31 76 5 42 61 10  
E-mail: info@linak.nl  
www.linak.nl

### NEW ZEALAND

LINAK New Zealand Ltd.  
Phone: +64 9580 2071  
Fax: +64 9580 2072  
E-mail: nzsales@linak.com.au  
www.linak.co.nz

### NORWAY

LINAK Norge AS  
Phone: +47 32 82 90 90  
Fax: +47 32 82 90 98  
E-mail: info@linak.no  
www.linak.no

### POLAND

LINAK Polska  
Phone: +48 (22) 500 28 74  
Fax: +48 (22) 500 28 75  
E-mail: dkreh@linak.dk  
www.linak.pl

### REPUBLIC OF KOREA

LINAK Korea Ltd.  
Phone: +82-(0)2-6231-1515  
Fax: +82-(0)2-6231-1516  
E-mail: scully@linak.kr  
www.linak.kr

### RUSSIAN FEDERATION

000 LINAK  
Phone: +7 495 280 14 26  
Fax: +7 495 687 14 26  
E-mail: info@linak.ru  
www.linak.ru

### SPAIN

LINAK Actuadores, S.L.u  
Phone: +34 93 588 27 77  
Fax: +34 93 588 27 85  
E-mail: esma@linak.es  
www.linak.es

### SWEDEN

LINAK Scandinavia AB  
Phone: +46 8 732 20 00  
Fax: +46 8 732 20 50  
E-mail: info@linak.se  
www.linak.se

### SWITZERLAND

LINAK AG  
Phone: +41 43 388 31 88  
Fax: +41 43 388 31 87  
E-mail: info@linak.ch  
www.linak.ch

### TAIWAN

LINAK A/S Taiwan Representative Office  
Phone: +886 2 27290068  
Fax: +886 2 27290096  
Mobile: +886 989292100  
E-mail: michael.chen@linak.com.tw  
www.linak.com.tw

### TURKEY

LINAK İth. İhr. San. ve Tic. A.Ş.  
Phone: +90 312 4726338  
Fax: +90 312 4726635  
E-mail: info@linak.com.tr  
www.linak.com.tr

### UNITED KINGDOM

LINAK UK Limited  
Phone: +44 (0)121 544 2211  
Fax: +44 (0)121 544 2552  
E-mail: info@linak.co.uk  
www.linak.co.uk

## DISTRIBUTORS

### ARGENTINA

Novotec Argentina SRL  
Phone: 011-4303-8989/8900  
Fax: 011-4032-0184  
E-mail: info@novotecargentina.com  
www.novotecargentina.com

### AUSTRALIA

Ballarat Industrial Supplies  
www.ballind.com.au

BL Shipways & Co  
www.blshipway.com.au

Gas Strut Marine and Industrial  
www.gasstrutmarine.com.au

Prime Motion & Control  
www.primemhd.com.au

West Vic Industrial Supplies  
www.westvicindustrial.com.au

### COLOMBIA

MEM Ltda  
Phone: +57(1) 334-7666  
Fax: +57(1) 282-1684  
E-mail: servicioalcliente@memitda.com.co  
www.memitda.com.co

### INDIA

Mechatronics Control Equipments India Pvt Ltd  
Phone: +91-44-28558484/85,  
E-mail: bala@mechatronicscontrol.com  
www.mechatronicscontrol.com

### INDONESIA

Pt. Himalaya Everest Jaya  
Phone: +62 221 544 8956/8965,  
Fax: +62 221 619 4658/1925  
E-mail: hejplastic-div@centrin.net.id  
www.hej.co.id

### IRAN

Bod Inc.  
Phone: +98 2188998635-6  
Fax: +98 2188954481  
E-mail: info@bod.ir  
www.bod.ir

### RUSSIAN FEDERATION

000 FAM  
Phone: +7 812 3319333  
Fax: +7 812 3271454  
E-mail: purchase@fam-drive.ru  
www.fam-drive.ru

### SINGAPORE

Servo Dynamics Pte. Ltd.  
Phone: +65 6844 0288  
Fax: +65 6844 0070  
E-mail: servodynamics@servo.com.sg  
www.servo.com.sg

### SOUTH AFRICA

Industrial Specialised Applications CC  
Phone: +27 11 312 2292 or +27 11 2077600 (Switch Board)  
Fax: +27 11 315 6999  
E-mail: garth@isagroup.co.za  
www.isaza.co.za

### UNITED ARAB EMIRATES

Mechatronics  
Phone: +971 4 267 4311  
Fax: +971 4 267 4312  
E-mail: mechtron@emirates.net.ae  
www.mechtronics.ae

For contact details on other countries please visit [www.linak.com](http://www.linak.com) or contact:

### LINAK INTERNATIONAL

Phone: +45 73 15 15 15  
Fax: +45 74 45 90 10  
Fax: +45 73 15 16 13 (Sales)  
E-mail: info@linak.com  
www.linak.com

## Terms of use

The user is responsible for determining the suitability of LINAK products for specific application. LINAK takes great care in providing accurate and up-to-date information on its products.

However, due to continuous development in order to improve its products, LINAK products are subject to frequent modifications and changes without prior notice. Therefore, LINAK cannot guarantee the correct and actual status of said information on its products.

While LINAK uses its best efforts to fulfill orders, LINAK cannot, for the same reasons as mentioned above, guarantee the availability of any particular product. Therefore, LINAK reserves the right to discontinue the sale of any product displayed on its website or listed in its catalogues or other written material drawn up by LINAK.

All sales are subject to the Standard Terms of Sale and Delivery for LINAK. For a copy hereof, please contact LINAK.



WE IMPROVE YOUR LIFE